

# Exploring Trajectories of Government Bonds for Debt Planning Using Machine Learning Models

Samrajya Raj Acharya<sup>a</sup>, Aayush Man Regmi<sup>ib</sup> and Kanhaiya Jha<sup>c</sup>

<sup>a</sup>B.Sc., Department of Mathematics, School of Science, Kathmandu University; <sup>b</sup>Data Scientist and Researcher collaborating with faculties of Department of Mathematics, School of Science, Kathmandu University; <sup>c</sup>Professor, Department of Mathematics, School of Science, Kathmandu University

## ABSTRACT

Reliable projection of government bond markets is crucial for effective public debt management, development financing, and reducing rollover risks. In Nepal, bond markets serve as a key instrument for mobilizing resources, yet their future trajectories remain under-explored despite their growing role in fiscal planning. This study investigates the mathematical exploration and computational performance of time series models ARIMA, RNN, and LSTM are applied to the government bonds of Nepal. The analysis examines trends, seasonal patterns, and trajectories using descriptive statistics to capture underlying market behaviors. An optimal ARIMA order was identified to effectively capture the linear growth path, while the RNN demonstrated strong capability in learning nonlinear patterns and outperformed the other models in predictive accuracy on unseen data. In contrast, the LSTM model, constrained by the limited size of the dataset, showed weaker generalization despite achieving comparable or lower training errors. The results highlight that Nepal's bond market is characterized by a steady trajectory in Development Bonds, uncertainty in Citizen Saving Bonds, and weak participation in Foreign Employment Bonds, with total borrowing projected to rise. These findings suggest that while ARIMA emphasizes stability, deep learning approaches reveal momentum-driven growth potential, offering complementary perspectives. The paper aims to inform policymakers by presenting insights into how bond market forecasting may strengthen long-term development financing, mitigate refinancing risks, and foster wider participation in underutilized bonds, ultimately enhancing the effectiveness of debt management in Nepal.

## ARTICLE HISTORY

Received: 28 March 2025

Revised and

Resubmitted: 12 February 2026

Accepted: 9 March, 2026

## KEYWORDS

ARIMA, RNN, LSTM, Government Bonds, Descriptive statistics, Seasonal patterns, Performance metrics

## JEL CLASSIFICATION

C22, C45, C53, G12, G17

## I. Introduction

Government bonds aren't just technical tools, they form the backbone of a nation's fiscal strategy. They give both governments and investors a shared path to manage money, support development projects, and keep the economy steady (Horton 2025).

Despite the increasing importance in public debt and monetary management strategy, Nepal's government bonds still remain under-studied, particularly in how statistical analysis can inform fiscal and regulatory decision-making process. Developing markets

**CONTACT** Aayush Man Regmi  [aayushregmi.np@gmail.com](mailto:aayushregmi.np@gmail.com)  Data Scientist and Researcher collaborating with Department of Mathematics, School of Science, Kathmandu University

© 2026 Nepal Rastra Bank, Economic Research Department.

like Nepal are particularly prone to external shocks and fluctuating market pendulum, which makes it all the more important to have forecasting tools that are up to the task. While the Public Debt Management Office (PDMO) claims that Nepal's domestic debt reaches half of the country's Gross Domestic Product (GDP) to Rs. 2676000 million i.e.; equivalent to 46.91% of the nation's GDP in the current fiscal year 2024/25 that marks an addition of approximately Rs 250000 million in public debt during this fiscal year alone (PDMO, 2024). Relatively, neighboring countries show varying levels of government debt and approaches to debt management. In India, government debt stood at around 57.2% of nominal GDP in September 2024, reflecting a relatively stable fiscal position supported by active debt management and regular government securities auctions. Bangladesh reported a government debt level of 26.6% of GDP in December 2024, with gradual adoption of modern risk management and forecasting tools to strengthen debt planning. China's debt-to-GDP ratio was approximately 25.6% at the end of 2024, managed through a highly regulated, large-scale bond market with sophisticated debt issuance and centralized fiscal planning. In contrast, Pakistan's government debt reached 65.2% of GDP in June 2024, highlighting significant fiscal challenges and underscoring the importance of structured debt management and careful monitoring of fiscal sustainability. Examining these countries' experiences provides useful benchmarks for Nepal, helping to identify strategies that could strengthen domestic debt planning and improve the efficiency and stability of its bond market.

The bond market in Nepal is still in a developing stage compared to regional peers, characterized by relatively low liquidity, limited investor participation, and high sensitivity to macroeconomic shocks. Despite these challenges, government bonds play a crucial role in financing public expenditure and managing national debt efficiently. Effective debt planning is important not only to ensure fiscal sustainability but also to maintain investor confidence, stabilize interest rates, and reduce the cost of borrowing. In addition, it helps governments manage repayment schedules efficiently, minimizes the risk of excessive debt accumulation, and safeguards public finances against economic shocks. Proper planning also allows for strategic allocation of resources to priority development projects without compromising long-term financial stability, and provides policymakers with the tools to make informed decisions on debt issuance, refinancing, and risk management. Time series analysis plays a pivotal role in this context by facilitating concerned regulators to track trends in the prices, yields, and interest rates over time for various types of bonds (Box et al. 2008). Around the world, there's growing interest in predicting bond market behavior. Worldwide, many studies have looked into different parts of bond performance, from yields to price swings. But most of these works have either focused on well-established markets or focused into the technical side of forecasting models. To understand Nepal's bond market, the study begins with a detailed look at the trend of the market itself by constructing a detailed picture of the market's behavior over time for future forecast. Concise forecasting of these economic indicators particularly in current volatile economic situation is crucial, where even a small deviation in predictions of the securities can have substantial impacts on economic stability (Fama, 1970).

This study captures the historical Nepalese government bond performance and how these bonds have performed throughout years along with testing of both traditional statistical models and modern deep learning models, Recurrent Neural Network (RNN) and Long Short-Term Memory (LSTM) all within the context of our nation. The motivation behind initiating this study comes from the need to explore the trajectories of Nepal's bond market and how it is changing over time, especially given its inherent challenges of predicting trends in an uncertain environment. By referring the ARIMA method against RNN and LSTM techniques, the research also looks how closely each model's predictions align with each other. This evaluation is designed to guide future research and help give suggestions to the concerned authorities that fit the dynamic nature of Nepal's government bond market by linking global findings with the specifics of Nepal's financial scene, offering insights that are valuable both for academic researchers and for real-world policy makers.

## II. Literature Review

Understanding the way government bonds and securities perform is essential for a sustainable financial planning in order to identify the ownership patterns of government bonds. Time series analysis helps the policymakers track changes in bond prices, yields, and interest rates. Traditional models like ARIMA have been widely used for such purposes, advanced deep learning models such as RNNs and LSTMs offer an improvised accuracy by capturing complex patterns in financial data. In this section, we examine their application in bonds and financial forecasting providing key research findings.

In his 2014 study, Mohanty looks at how emerging markets are struggling to manage their bond markets as they become more connected to the global financial system. These markets are now more vulnerable to global financial shocks and volatility. This growing exposure is making it tougher for local policymakers to maintain stability and make sound economic decisions. The IMF (2021) looks at what influences bond flows and prices in emerging markets, highlighting the impact of both local economic health and global financial conditions. Using a risk-based approach, it helps identify vulnerabilities and guide policies to keep markets stable.

While Artificial Neural Networks (ANNs) were still in development phase, statistical methods like the Auto Regressive Integrated Moving Average (ARIMA) model were the standards for unravelling linear trends in data. ARIMA offered a reliable way to pick up on recurring patterns, cycles, and seasonal changes that quickly became a trusted tool for data analysts who needed a straightforward, dependable approach (Hyndman & Athanasopoulos, 2021). This method not only set the stage for future breakthroughs but also perfectly suited the day-to-day needs of professionals dealing with data that followed largely predictable, linear paths. The ARIMA model was first introduced by Box and Jenkins in the early 1970, in their book *Time Series Analysis: Forecasting and Control* (1976). Its statistical foundation was further developed by researchers like Brockwell and Davis in 1991 textbook *Time Series: Theory and Methods* presented the mathematical foundations and formulations of ARIMA models in deeper detail and addressed the estimation and inference procedures necessary to apply ARIMA effectively. Brockwell's work refined the mathemat-

ical tools for model selection and hypothesis testing, like the use of AIC for comparison and validation and validation of models. Hyndman and Athanasopoulos (2021) extended the methodology for ARIMA specializing on computational process with algorithms for model fitting and forecasting. ARIMA's strength lies in its ability to model stationary time series data which combines autoregression, moving averages, and differencing.

Zhuravka et al. (2019) applied the ARIMA model to forecast Ukraine's government debt, demonstrating its capability in short-term predictions despite challenges with non-stationary data. Petrică et al. (2016) figured out that ARIMA models are sensitive to outliers and volatility clustering. Chong and Soong (2021) evaluated various models, including ARIMA, for predicting the U.S. bond yield curve and found out while ARIMA models effectively forecast short-term yields, their accuracy declines over longer forecast range. Okyere and Nanga (2024) forecasted auction of 91-day treasury bill rates in Ghana by employing ARIMA models to predict weekly auction rates and found that the results indicated that the ARIMA (2,1,2) model was optimal for forecasting the average daily share price. Weißbach et al. (2006) evaluates the performance of ARIMA, in forecasting the monthly yield of US 10-year Treasury bonds studying that while the econometric model has a slight edge, the ARIMA model closely follows, indicating its effectiveness in capturing the underlying patterns in bond yield data. Ozturk et al. (2020) utilized ARIMA models to forecast treasury bond prices in Turkey, highlighting the model's capability to predict short-term bond price fluctuations. It has been noticed that while ARIMA has proven effective in financial forecasting, it is not left without limitations. Logubayom et al. (2013) employs ARIMA models to forecast the rates of 91-day and 182-day Treasury bills, finding out ARIMA (3,1,1) and ARIMA (1,1,0) as the most appropriate models.

To deal with nonlinearity ANNs has been used to identify intricate nonlinear relationships between dependent and independent variables (Tu, 1996). RNNs was introduced by notable physicist John Hopfield in 1982, based on the idea of recurrent series in mathematics and physics. Hopfield's work on associative memory models in neural networks laid the foundation for the architecture of RNN. Understanding the behavior of networks with feedback loops influenced concurrent developments in computational models for sequential data. Later on, RNN with backpropagation through time (BPTT) algorithm, was developed by Rumelhart, Williams, and Hinton in 1980. Elman in 1990 further extended the RNN architecture for time series and natural language processing. His work focused on the development of simple recurrent networks, which included context units to capture temporal dependencies in sequences that allowed RNNs to handle time series data effectively. Goodfellow et al. provided theoretical foundations of deep learning and RNN models in 2016, concentrating on optimizing neural network mathematically. Stege et al. (2021) integrated neural networks with cointegration analysis to derive swap rate forecasts for various interest rates, thereby improving stress testing accuracy in financial risk management. By integrating statistical and deep learning models, Castellani and Santos (2006) found out that it enhances the predictive accuracy of long-term government bond forecasts, using deep learning techniques in financial forecasting.

In the 1990s, Hochreiter and Schmidhuber made major contributions to the theoretical understanding of RNNs, by introducing LSTM architecture, which addressed the vanishing gradient problem. Hochreiter and Schmidhuber's work in 1997 demonstrated that LSTMs

could successfully capture long-term dependencies in sequential data by introducing the gating mechanisms. Researchers such as Bengio's 2009 worked on the deep networks and the exploration of deep architectures. In the 2010, more mathematicians and computer scientists worked on optimizing LSTM networks for efficiency and accuracy. Bahdanau et al. contributed to the development of attention mechanisms in sequence-to-sequence models, which enhanced the capabilities of LSTMs in tasks such as machine translation and time series forecasting.

Yao et al. (2024) developed a hybrid CNN-LSTM model that combines Convolutional Neural Networks (CNN) for processing unstructured text data and LSTM networks for analyzing time-series data, resulting in superior bond default risk prediction accuracy. Yu et al. (2024) integrated the Improved Complete Ensemble Empirical Mode Decomposition with Adaptive Noise (ICEEMDAN) technique with various machine learning models, such as LSTM, Temporal Convolutional Network (TCN), Transformer, and Autoformer, to forecast China's interbank bond transaction interest rates over extended periods. Abibasu and Choudhary (2022) on studying the Gulf Securities Market by using LSTM techniques to predict market values over a period of 20 years found the potential of LSTM models in forecasting market trends in Gulf countries modelled and found the extensive temporal dependencies present in the market.

Various comprehensive studies and in-depth reports have evaluated and tested the performance of ARIMA, RNN, and LSTM models in forecasting financial time series data. Dua et al. (2008) tested various forecasting models including to predict interest rates of Indian government securities with maturity periods over time. The study finds out that of all the models, the ARMA model generated the highest accurate predictions for securities with one-, five-, and ten-year maturities. In order to enhance US Treasury bond forecasts. Li et al. (2024) created LSTM models that combines market sentiment to economic data. Their findings suggest that LSTM models perform better than conventional recurrent neural networks in capturing long-term temporal dependencies. Siami-Namini et al. (2018) compared ARIMA and LSTM models for economic and financial time series forecasting, concluding that LSTM models significantly outperformed ARIMA in terms of prediction accuracy. In addition, Regmi and Acharya (2025) employed statistical and deep learning models to model and forecast Nepal's foreign assets and liabilities, demonstrating the effectiveness of integrating linear and nonlinear approaches in financial modeling of the banking sector. Furthermore, hybrid ARIMA-ANN approach for GDP forecasting in Nepal was illustrated by Uprety and Chaudhary (2023), who combined ANNs for nonlinear patterns with ARIMA for linear trends.

### **III. Mathematical Models and Methodology**

#### **3.1 ARIMA Model**

ARIMA identifies the optimal order of the process, which includes three components: the autoregressive (AR), denoted by ' $p$ ', that models the dependency between an observation and a number of lagged observations, the previous time steps. The moving average (MA), denoted by ' $q$ ', involves the dependency between an observation and a residual error from

a moving average model applied to lagged observations. and the differencing term (I), represented by 'd', which helps to make the data stationary.

$$AR(p): Y_t = \phi_1 Y_{(t-1)} + \phi_2 Y_{(t-2)} + \dots + \phi_p Y_{(t-p)} + \epsilon_t \quad (1)$$

$$I(d): \Delta Y_t = Y_t - Y_{(t-1)} \quad (2)$$

$$MA(q): Y_t = \mu + \epsilon_t + \theta_1 \epsilon_{(t-1)} + \theta_2 \epsilon_{(t-2)} + \dots + \theta_q \epsilon_{(t-q)} \quad (3)$$

The ARIMA model is essentially a special case of the ARMA model.

The general ARMA( $p, q$ ) equation is given by:

$$Y_t = c + \phi_1 Y_{(t-1)} + \phi_2 Y_{(t-2)} + \dots + \phi_p Y_{(t-p)} + \epsilon_t - \theta_1 \epsilon_{(t-1)} - \theta_2 \epsilon_{(t-2)} - \dots - \theta_q \epsilon_{(t-q)} \quad (4)$$

$$Y_t = c + \sum_{i=1}^p \phi_i Y_{t-i} + \epsilon_t - \sum_{j=1}^q \theta_j \epsilon_{(t-j)} \quad (5)$$

Using the backward shift operator  $B$ , where  $B^i Y_t = Y_{t-i}$ , ARMA model can be rewritten as:

$$Y_t = c + \sum_{i=1}^p \phi_i Y_t B^i + \epsilon_t - \sum_{j=1}^q \theta_j \epsilon_t B^j \quad (6)$$

Rearranging we obtain ARMA model as follows:

$$\left(1 - \sum_{i=1}^p \phi_i B^i\right) Y_t = c + \left(1 - \sum_{j=1}^q \theta_j B^j\right) \epsilon_t \quad (7)$$

Its compact form:

$$\Phi_p(B) Y_t = c + \Theta_q(B) \epsilon_t \quad (8)$$

Where,

$$\Phi_p(B) = 1 - \sum_{i=1}^p \phi_i B^i, \quad \Theta_q(B) = 1 - \sum_{j=1}^q \theta_j B^j$$

One major limitation of ARMA models is their requirement for stationarity. Many real-world time series exhibit trends or non-stationary behavior, necessitating a differencing step by substituting  $(1-B)^d Y_t$  for  $Y_t$ . This leads to the ARIMA model formulation:

$$\Phi_p(B) (1-B)^d Y_t = c + \Theta_q(B) \epsilon_t \quad (9)$$

The ADF test is used to check whether a time series is stationary by testing the null hypothesis that the series has a unit root, indicating it is non-stationary. Its regression model is:

$$\Delta y_t = \alpha + \beta t + \delta y_{(t-1)} + \sum_{i=1}^p \gamma_i \Delta y_{(t-i)} + u_t \quad (10)$$

### 3.2 Recurrent Neural Networks (RNN) Model

RNNs are a class of neural networks designed for sequence data, where the output at a given time depends not only on the current input but also on previous inputs. RNNs are particularly well-suited for time series forecasting and sequential data modeling because they can capture temporal dependencies over time

### **Input Layer**

The input layer which receives the input data at each time step is responsible for receiving the sequence of input vectors over multiple time steps in  $T$  time steps which is mapped to the hidden layer using a weight matrix, which transforms the input into a new representation. It is represented as:

$$h_t = f(W_x \cdot x_t + b_x) \quad (11)$$

### **Hidden Layer(s)**

The hidden layer consists of recurrent units that process the data sequentially, updating their hidden state based on the current input and previous state. It maintains memory across time steps and is updated recursively. It is represented as:

$$h_t = f(W_h \cdot h_{(t-1)} + W_x \cdot x_t + b_h) \quad (12)$$

### **Output Layer Formulation**

The output layer of an RNN is where predictions are made, and it may involve a linear or non-linear transformation of the hidden state depending on the nature of the prediction. It typically applies a transformation to the hidden state, which can be linear or non-linear, depending on the nature of the problem. It is represented as:

$$y_t = W_y \cdot h_t + b_y \quad (13)$$

## **3.3 Long Short-Term Memory (LSTM) Networks**

The layers of LSTM network include the input layer, the LSTM cell layers (which consist of input, forget, and output gates to control the flow of information), hidden state for backpropagation and the output layer, where the final predictions are made based on the processed information from the LSTM cells.

### **Input Layer**

The input layer receives the sequence of input vectors over  $T$  time steps and maps them to the LSTM hidden layer using a weight matrix. It is represented as:

$$h_t = f(W_x \cdot x_t + b_x) \quad (14)$$

### **Hidden Layer(s)**

Each LSTM unit consists of:

- **Forget Gate:** Determines how much past information should be discarded. It is represented as:

$$f_t = \sigma(W_f \cdot [h_{t-1}, x_t] + b_f) \quad (15)$$

- **Input Gate:** Controls how much new information to store. It is represented as:

$$i_t = \sigma(W_i \cdot [h_{t-1}, x_t] + b_i) \quad (16)$$



- **Candidate Cell State:** Generates new information to be added to the cell state, represented as:

$$\tilde{C}_t = \tanh(W_c \cdot [h_{t-1}, x_t] + b_c) \quad (17)$$

- **Cell State Update:** Combines previous state and new information. It is represented as:

$$C_t = f_t \odot C_{t-1} + i_t \odot \tilde{C}_t \quad (18)$$

- **Output Gate:** Decides the hidden state update. It is represented as:

$$o_t = \sigma(W_o \cdot [h_{t-1}, x_t] + b_o) \quad (19)$$

- **Hidden State Update:**

$$h_t = o_t \odot \tanh(C_t) \quad (20)$$

### Output Layer

The final prediction is computed as:

$$y_t = W_y \cdot h_t + b_y \quad (21)$$

In this study, we use ARIMA, RNN and LSTM for modelling the temporal data. The data we utilized is sourced from the Nepal Rastra Bank's database. This study includes a modelling approach for 5 different indicators of government bonds and treasury bills namely: Treasury Bills, Development Bonds, Citizen Savings Bonds, Foreign Employment Bonds and Total Bonds & Treasury Bills.

Total Bonds & Treasury Bills is the summation of all the sub-headings included in the government bonds and treasury bills; it includes data from 1993 to 2024. Similarly, treasury bills and development bonds also range from 1993 to 2024 whereas data for citizen savings bonds and Foreign Employment bonds ranges from 2002 to 2024 and 2010 to 2024 respectively. Furthermore, national saving bonds and special bonds are not mentioned in this study because of the unavailability of data from 2019 onwards for national saving bonds and 2013 onwards for special bonds.

We illustrate the data and provide descriptive statistics for each sub-heading. The data analysis and modelling are conducted using the open-source programming language Python version 3.10

**Table 1:** Descriptive Statistics of Time Series Data for Each Sub-heading (In Million Rupees)

Financial Indicators	Mean	Median	Standard Deviation	Max	Min	Count	Year Range
Total Bonds & Treasury Bills	259663.60	116056.40	325210.20	1176986.00	25456.00	32	1993-2024
Development Bonds	132166.00	25606.95	216591.00	761947.00	3042.20	32	1993-2024
Treasury Bills	111878.72	85774.00	116287.16	457815.60	4403.20	32	1993-2024
Citizen Saving Bonds	4974.88	4433.64	3374.54	11120.10	628.10	23	2002-2024
Foreign Employment Bonds	241.21	190.20	191.76	529.70	4.00	15	2010-2024

Source: Author's calculation

The descriptive statistics in Table 1 show how Nepal's domestic borrowing using government bonds and treasury bills has changed over time. Total bonds and treasury bills have increased, primarily because the country now relies upon more long-term Development Bonds to pay for infrastructure and budget projects. The high average and top values show these bonds are being used more over time, matching Nepal's need for growth and budget support. Treasury Bills, even though they are smaller in value, still play a key role in helping the government manage short-term cash needs. Citizen Saving Bonds, started in 2002, have steady but small use, showing an effort to get people to save money through simple investment tools. Foreign Employment Bonds, made to attract money from Nepalis working abroad, have very low use, showing it's hard to get the diaspora to invest for the long term. Overall, the statistics show Nepal is slowly expanding and changing its borrowing tools to match different timeframes and types of investors.

### 3.4 Evaluation Metrics

Three scientifically proven metrics, MAE, MSE, RMSE are used to evaluate the performance of our models. In this study, we employed the computationally efficient Auto-ARIMA method to identify the best ARIMA model for our data. It evaluates the models using statistical criteria, including AIC, BIC and HQIC.

We need to pre-process the data before building and training the model. For RNN *log* transformation of the data is done to stabilize the variance and reduce skewness. For LSTM, Min-Max scaler is implemented to transform the data into a desired range i.e. (0 to 1). The window size of 5 is taken into consideration for Total Bonds & Treasury Bills, Development Bonds and Treasury Bills because the data size is greater for these financial indicators whereas a window size of 2 is taken for Citizen Saving Bonds and Foreign Employment Bonds because of lesser data size.

We forecast each of the included financial indicators using the models described. We project future values over the '*n*' time-periods (in years), where *n* is determined by the total length of the available dataset. Specifically, we set *n* to be one-fourth of the total data length. This approach ensures that we retain enough data for robust model training while still providing a meaningful forecast horizon for evaluation.

**Table 2:** Hyperparameters for RNN and LSTM Models

Hyperparameters	RNN	LSTM
Architecture	32-32-32	32-32-32
Epoch	100	100
Learning rate	0.001	0.001
Activation Function	Rectified Linear Unit ( <i>ReLU</i> )	Rectified Linear Unit ( <i>ReLU</i> )
Optimizer	Adam	Adam
Loss	Mean squared error	Mean squared error
Accuracy	Mean absolute error	Mean absolute error

Source: Author's calculation

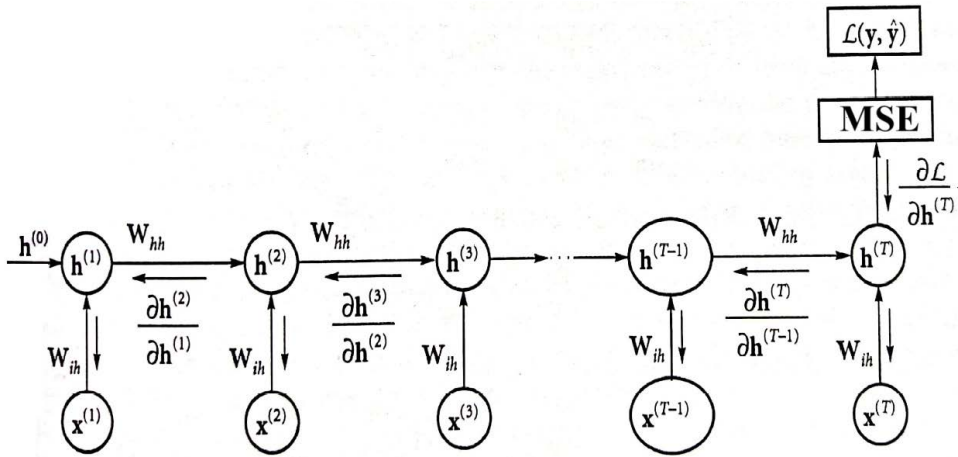

**Figure 1:** Architecture of RNN and its Training Using Back Propagation Through Time (BPTT). Source: Author (Based on derivations below)

### 3.5 Training RNN Using Backpropagation Through Time (BPTT)

The training of our RNN involves adjusting its parameters  $W_{hh}$ ,  $W_{ih}$  and  $b_h$  to minimize the loss function in which we choose mean squared error, mean absolute error and root mean squared error. To measure the difference between the predicted values and the actual values and we choose mean absolute error to evaluate the accuracy of a model's predictions. They are computed as:

$$MSE = \frac{1}{n} \sum_{i=1}^n (y_i - \hat{y}_i)^2 \tag{22}$$

$$MAE = \frac{1}{n} \sum_{i=1}^n |y_i - \hat{y}_i| \tag{23}$$

$$RMSE = \sqrt{\frac{1}{n} \sum_{i=1}^n (y_i - \hat{y}_i)^2} \tag{24}$$

For our training done using Backpropagation Through Time (BPTT) which is an extension of standard backpropagation for sequential models. Its loss function is:

$$L = \sum_{t=1}^T L(y_t, \hat{y}_t) \tag{25}$$

The gradients of the loss function with respect to the parameters is computed using chain rule. We have declared  $T = 32$  neurons for each layer and the network is 3 layers deep. The gradient of  $L$  for hidden weights  $W_{hh}$  is

$$\frac{\partial L}{\partial W_{hh}} = \frac{\partial h(T)}{\partial L} \cdot \frac{\partial W_{hh}}{\partial h(T)} \tag{26}$$

The gradient for hidden weight with respect to the recurrent weight matrix  $W_{hh}$  requires backpropagation through time:

$$\frac{\partial L}{\partial W_{hh}} = \sum_{k=1}^T \frac{\partial h(T)}{\partial L} \cdot \frac{\partial h(k)}{\partial h(T)} \cdot \frac{\partial W_{hh}}{\partial h(k)} \tag{27}$$

Since,  $\frac{\partial h(k)}{\partial h(T)}$  is a chain rule, the gradient (25) can be written as:

$$\frac{\partial L}{\partial W_{hh}} = \sum_{t=1}^T \left( \frac{\partial h(T)}{\partial L} \prod_{k=1}^{T-1} \frac{\partial h(k)}{\partial h(k+1)} \frac{\partial W_{hh}}{\partial h(t)} \right) \quad (28)$$

The gradient with respect to  $W_{ih}$  is,

$$\frac{\partial W_{ih}}{\partial L} = \frac{\partial h(T)}{\partial L} \cdot \frac{\partial W_{ih}}{\partial h(T)} \quad (29)$$

This process helps our RNN model learn the complex temporal dependencies in sequential data, making it effective for tasks like time series forecasting and natural language processing.

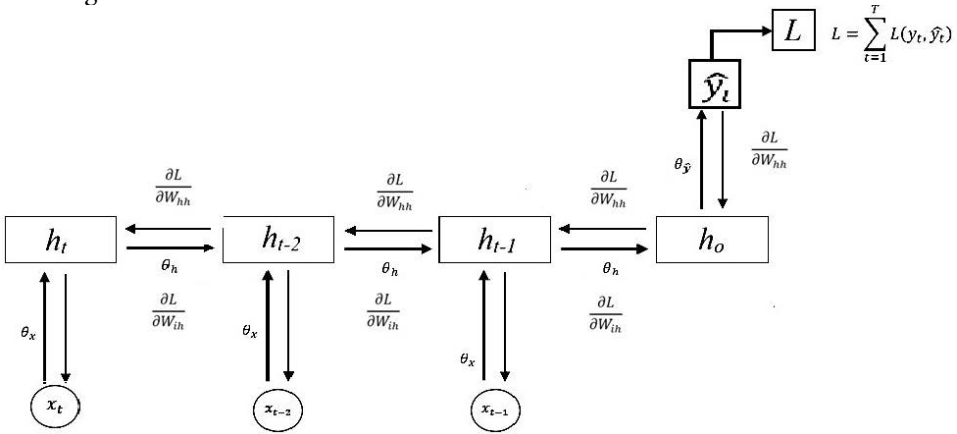

**Figure 2:** Architecture of LSTM and its Training Using Back Propagation Through Time (BPTT). Source: Author (Based on Derivation Below)

### 3.6 Training LSTM Using Backpropagation Through Time (BPTT)

Training an LSTM involves minimizing a loss function using Backpropagation Through Time (BPTT). The procedure is similar to training RNNs, but with more complex computations due to the presence of the gates. Let  $\hat{y}_t$  be the predicted output and  $y_t$  be the actual output at time  $t$ . The total loss for a sequence of length  $T$  is:

$$L = \sum_{t=1}^T L(y_t, \hat{y}_t) \quad (30)$$

where  $L$  is the loss function.

The gradients for the parameters  $W_{hh}, W_{ih}$  are computed using the chain rule, backpropagating the error through time. The gradient of the loss with respect to the forget gate weight  $W_{hh}$  is computed using:

$$\frac{\partial L}{\partial W_{hh}} = \sum_{t=1}^T \frac{\partial L}{\partial C_t} \cdot \frac{\partial C_t}{\partial W_{hh}} \quad (31)$$

where the derivatives are computed based on the interaction between the gates and the memory cell. Similarly, the gradients for the input gate weights are computed:

$$\frac{\partial L}{\partial W_{ih}} = \sum_{t=1}^T \frac{\partial L}{\partial C_t} \cdot \frac{\partial C_t}{\partial W_{ih}} \quad (32)$$

## V. Results and Discussion

### 4.1 ARIMA Model

We conducted ADF test to check stationary of the data. The indicators with a  $p$ -value greater than 0.05 signifies that the data does not follow stationarity and the indicator with  $p$ -value less than 0.05 denotes that the data follows stationarity<sup>1</sup>.

**Table 3:** Model Selection for ARIMA Forecast

Indicators	Models	AIC	Training time
Total Bonds and Treasury Bills	ARIMA (0,2,0)	708.100	0.01 second
Development Bonds	ARIMA (0,2,0)	688.045	0.01 second
Treasury Bills	ARIMA (1,1,0)	728.192	0.01 second
Citizen Saving Bonds	ARIMA (0,1,0)	384.132	0.01 second
Foreign Employment Bonds	ARIMA (2,0,1)	183.682	0.12 second

Source: Author's calculation

Among all the implemented ARIMA models for forecasting each indicator, we have selected the best one, as shown in the table above. This model was chosen based on its lowest AIC and the shortest training time.

The Total Bonds and Treasury Bills indicator follows an ARIMA (0,2,0) order. This shows a strong growth pattern, where the second-order difference means the value is not only rising but doing so at a fast pace over time. Economically, this may reflect an expansionary fiscal policy where the government issues more debt to cover rising expenses. The lack of AR and MA orders denotes that short-term fluctuations or past shocks have little effect on this indicator.

Development bonds follow an ARIMA (0,2,0) order. This pattern denotes the accelerating growth, suggesting that government spending on development projects is not only steady but growing more and more over time. With null AR or MA terms, it reinforces that the growth is driven by an underlying trend, mostly free from short-term economic noise or past deviations. This may arise from increasing capital needs as the economy grows and from a strategic shift toward prioritizing long-term bonds focusing on long lasting projects for policy planning.

Treasury bills have an ARIMA (1,1,0) order. The first-order differencing shows steady, linear growth, while the AR (1) denotes that the current value relies on its previous value. The lack of an MA term specifies that random shocks do not affect the short-term pattern. Economically, this pattern closely follows the essence of treasury bills being used as tools for short-term liquidity and cash flow management because of regular budget cycles and routine debt rollovers.

Citizen Saving Bonds follow an ARIMA (0,1,0) order that depicts linear growth. The single differencing term directs a constant rate of increase, while the lack of AR or MA parts implies little dependence on past values or shocks. Economically, this reflects the stable and predictable nature of these bonds reflecting the plain purpose of these bonds as

<sup>1</sup> See Appendix I for the ADF test

a dependable indicator of long-term savings.

Foreign Employment Bonds follow a more intricate ARIMA (2,0,1) model. With no differencing, there's no steady long-term growth. The AR (2) means the current value depends on the last two values, and the MA (1) represents recent sudden changes have an impact. This shows these bonds are more unstable and easily affected by external factors. These bonds seem reactive to current conditions, lacking a steady upward path. This volatility fits with their reliance on international economic variables, which are inherently less predictable than domestic fiscal policies or local investor behavior.

### 4.2 Forecast for ARIMA

In this we forecast the future values for each economic indicators with upper and lower confidence level and provide a graphical representation of the Total Bonds and Treasury Bills<sup>2</sup>.

**Table 4:** ARIMA Forecast of Total Bonds & Treasury Bills (In Million Rupees)

Year	Forecast Amount	CI Lower	CI Upper
2025	1228784.4	1169561	1288007
2026	1280582.5	1148156	1413009
2027	1332380.6	1110789	1553973
2028	1384178.7	1059801	1708556
2029	1435976.8	996767.6	1875186
2030	1487774.9	922823.9	2052726
2031	1539573.0	838837.5	2240308
2032	1591371.1	745498.1	2437244

Source: Author's calculation

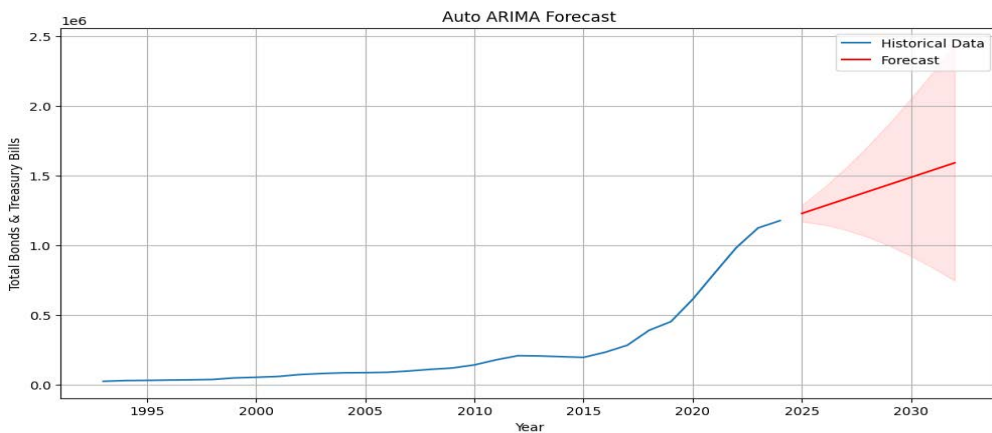

Source: Author's calculation

**Figure 3:** ARIMA Forecast of Total Bonds & Treasury Bills (In Million Rupees)

The ARIMA forecast for Total Bonds and Treasury Bills as shown in Table 4 and Figure 3 explains that the value of Government Bonds and Treasury Bills is expected to grow steadily from 2025 to 2032. This suggests that the government will likely borrow more in

<sup>2</sup> See appendix for forecast of rest of the financial indicators)

the coming years, possibly to fund infrastructure projects, manage debt, or support the economy. However, the wide range of possible outcomes also highlights how uncertain long-term predictions can be. This trend brings both risks and chances. On one side, it raises questions about whether the government can handle this debt well, how it might affect private business investments, and if it could make monetary policy harder. On the other side, it could help the economy grow and create new chances for investment. For policymakers, it means they need to carefully balance using debt to build the country and avoiding the risks of borrowing too much. For investors, it points to a market with good chances but also some risk.

### 4.3 Forecast for RNN and LSTM models:

The process of building the RNN and LSTM models is carried out using a training set of 80% and a testing set of 20% for the data included. To make this experiment as fair as possible we have implemented the same number of hidden layers, activation function, learning rate, optimizer and epoch for both the models. The performance of the model is measured by MAE, MSE, RMSE<sup>3</sup>.

In this we forecast the future values for each economic indicators and provide a graphical representation of the Total Bonds and Treasury Bills<sup>4</sup>.

**Table 5:** RNN and LSTM Model Forecast of Total Bonds & Treasury Bills (In Million Rupees)

Year	RNN Forecast Amount	LSTM Forecast Amount
2025	1154152.250	1115167.500
2026	1169626.125	1284832.250
2027	1218346.625	1358582.250
2028	1251340.875	1449724.250
2029	1268232.750	1809940
2030	1290705.750	2257843.250
2031	1319705.750	3445776.750
2032	1345872.000	7986674.000

Source: Author's calculation

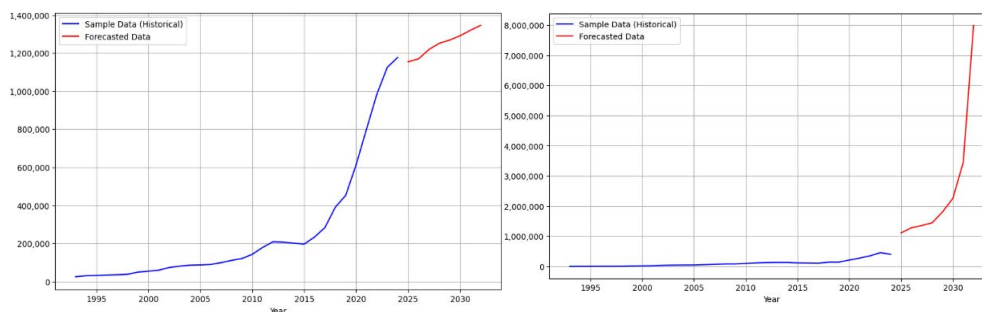

Source: Author's calculation

**Figure 4:** RNN (left) and LSTM (right) Prediction for Total Bonds & Treasury Bills.

<sup>3</sup> See Appendix I for the model performance

<sup>4</sup> See Appendix I and II for forecast of rest of the indicators

From the model performance tables<sup>5</sup> of both deep learning models used in this study, we observe that RNN performs significantly better than LSTM across all metrics for government bonds and treasury bills indicators. This holds true for both the training and testing data.

The RNN model predicts steady and moderate growth path, with the economic indicator rising from 2025 to 2032. This forecast points to an economy that is stable and predictable, where growth comes from steady government policies, stable global trade, and gradual improvements in productivity and consumer demand.

The LSTM model shows a sharp and fast-growing trend from 2025 to 2032. This bold forecast suggests a major economic growth, possibly caused by external economic changes. The rapid growth, especially after 2029, shows a compounding effect early gains lead to more activity through network effects or scaling up. But this kind of fast growth carries big risks, as such high rates are rare without strong reasons, raising doubts about how realistic the forecast is without clear proof of major drivers. The RNN model offers a careful forecast, assuming the economy stays on its current path, making it a helpful guide for what could happen if nothing major changes.

Meanwhile, the LSTM model expects exponential growth, which is more favorable but risky at the same time, potentially fueled by significant structural changes. In real life, the future of the economy will depend on many things like government actions, new technology, global peace, and surprise events that are hard to predict. This shows the limits of only using past data or neural network models, since they may follow different trends or miss big changes caused by outside factors.

For the individual bond categories<sup>6</sup>, the results can be summarized as follows:

For development bonds, ARIMA forecasts a stable linear increase with moderate uncertainty. RNN forecast shows a rapid upward trajectory, indicating the possibility of strong future growth momentum. LSTM produces a sharp acceleration in growth beyond 2025, suggesting the model anticipates compounding effects in development bonds issuance.

For Treasury bills, the ARIMA model shows a decline in 2025, followed by a steady rise in later years, while the RNN and LSTM models both show a steady decrease over the whole forecast period. For Citizen Saving Bonds, the ARIMA model shows very little growth, just continuing the trend already seen in the data. Likewise, the RNN models a decline, while the LSTM shows growth that increases slowly and then flattens out.

For Foreign Employment Bonds, the ARIMA model shows a small drop for the first three years, then a rise starting in the fourth year. The RNN depicts exhibits logarithmic-like growth in the initial years and the LSTM model shows steady upward growth. For Total Bonds and Treasury Bills, the ARIMA model shows a sharp rise like that of development bonds. In contrast, the RNN model follows a straight-line growth path, while the LSTM model shows a curve that opens upward, like a rising parabola.

---

<sup>5</sup> See Appendix I

<sup>6</sup> See Appendix I and II

**Table 6:** RNN vs LSTM vs ARIMA Model Performance for Total Bonds & Treasury Bills (In Million Rupees)

Model	MAE train	MSE train	RMSE train	MAE test	MSE test	RMSE test
RNN	7378.32	120198441.01	10963.50	146707.95	25114951773.33	158476.90
LSTM	15792.06	411907168.00	20295.50	355477.72	147354353664	383867.62
ARIMA	7872.97	99562711.57	9978.11	478012.47	305881100335.27	553065.18

Source: Author's Calculation

While comparing the performance of ARIMA, RNN and LSTM in this study, we fitted three of the models on Total Bonds & Treasury Bills data because it is the summation of all the economic indicators used in this study along with National Saving bonds and Special bonds. This ensures the inclusion of every government bond and treasury bills of Nepal.

In the above table we have performed comparative analysis for the RNN, LSTM, and ARIMA. The models were evaluated using both training and test datasets. The RNN model demonstrated competitive training performance, with a MAE of 7378.32 and a corresponding RMSE of 10963.50. Notably, on the test set, the RNN achieved a MAE of 146707.95, outperforming both the ARIMA model and the LSTM model. Although the ARIMA model showed a comparable training MAE of 7872.97, its relatively lower RMSE of 9978.11 and substantially inferior test performance suggest that its predictive capability on unseen data is limited. Similarly, the LSTM model's elevated training errors (MAE of 15792.06 and RMSE of 20295.50) indicate that it may be overfitting or suggest that the data may not have long-term dependencies due to lack of inherent complexity and large time windowed dataset for training. Consequently, these findings highlight the RNN model's superior generalization ability, making it the most effective option among the three models for forecasting in this government bond and treasury bills of Nepal.

## V. Conclusion

This study analyzed the historical performance of various Nepalese government bonds and applied three forecasting models: ARIMA, RNN, and LSTM to understand future trends. The results provide meaningful insights into potential debt market behavior, highlighting areas where policy attention is warranted.

The consistent rise followed by a steady trend in Development Bonds across all three models (ARIMA, RNN, and LSTM) suggests that there will be sustained demand for long-term government financing instruments in Nepal. This indicates that Development Bonds will continue to play a crucial role in funding infrastructure and other national development projects. However, this projected growth also brings an important challenge: the risk of refinancing large volumes of debt once these bonds reach maturity. Financial authorities should therefore consider adopting strategies such as staggered maturities, bond buyback programs, or the development of secondary markets to manage rollover risks effectively. Additionally, as Development Bonds are often subscribed to by institutional investors, policies that encourage wider retail participation could help diversify the investor base and reduce concentration risks.

The projected decline in Treasury Bills, particularly evident in the RNN and LSTM forecasts, conveys a shift away from short-term borrowing. This may reflect either a reduced need for short-term liquidity financing in the future or a recognition that Nepal has been overly reliant on short-term debt instruments in recent years. From a policy perspective, this could be a favorable signal, as reducing dependence on short-term borrowing can help stabilize interest costs and mitigate refinancing pressures. Nonetheless, short-term instruments remain an important tool for liquidity management, so the government must maintain a balanced mix of short- and long-term securities. A well-designed debt strategy would therefore involve optimizing the maturity structure of borrowing to keep financing costs manageable while minimizing rollover risks.

The forecasts for Citizen Saving Bonds display a high degree of divergence across models, reflecting uncertainty regarding public confidence in these instruments. The ARIMA model indicates stagnation, while the RNN shows a decline and the LSTM suggests modest growth followed by flattening. This divergence highlights the importance of investor sentiment and accessibility in determining the future trajectory of Citizen Saving Bonds. To enhance participation, the government could strengthen awareness campaigns, simplify subscription procedures, and expand access to rural populations where savings remain largely outside formal financial channels. Increasing trust and ease of participation could transform Citizen Saving Bonds into a more robust source of domestic financing.

Foreign Employment Bonds show weaker participation and less predictable trends across models, underscoring the limited engagement of Nepali migrant workers with these instruments. Given the large volume of remittance inflows into Nepal, this represents a missed opportunity for mobilizing diaspora capital into development financing. Policymakers should consider strategies such as digital subscription platforms, tailored investment incentives, and flexible redemption policies to attract migrant workers. Collaborating with international money transfer operators and foreign employment agencies could further integrate these bonds into the financial habits of overseas workers, thereby broadening the investor base.

The forecasts for Total Bonds and Treasury Bills point to significant growth, especially in the ARIMA projections, which implies that Nepal's aggregate public debt may increase considerably in the near future. While an increase in government borrowing is not inherently problematic, especially if directed toward productive infrastructure investments authorities must carefully manage the associated risks. This requires continuous monitoring of debt sustainability, prudent interest rate management, transparent communication with investors, and proactive engagement with credit rating agencies. Strengthening the government's debt management framework and aligning borrowing with medium-term fiscal objectives will be essential to maintain both investor confidence and financial stability.

Overall, the comparative analysis of ARIMA, RNN, and LSTM forecasts provides valuable insights into the future dynamics of Nepal's bond market. By combining the stability-oriented outlook of ARIMA with the momentum-driven signals of neural network models, policymakers can craft a more resilient debt strategy. These forecasts highlight

the importance of diversifying financing sources, managing maturity risks, improving investor outreach, and leveraging remittances. If acted upon, these measures can help Nepal build a more robust and sustainable public debt management system that supports long-term economic development.

The future work, aims to improve the accuracy and depth of forecasts by incorporating additional variables such as short-term bond time maturity periods of treasury bills. Similarly, foreseeing to work upon composition of interest rates of development bonds since it is long term in nature which is find more substantial as compared to others along with its investor categories. These factors are key to understanding how public debt is structured and what it could mean in the long run, since they directly influence risk levels, repayment timing, and how investors behave. We also plan to look into hybrid forecasting models that combine the strengths of ARIMA, RNN, and LSTM. By blending ARIMA's ability to track straight-line trends with the RNN and LSTM models' skills in learning patterns over time and handling complex changes, we could make the predictions much more accurate and reliable.

Furthermore, the importance of examining the composition and maturity distribution of various debt instruments in greater detail is mandatory. Discussing the balance between short-term and long-term borrowing, rollover risks, and the evolution of debt instruments over time can provide more meaningful policy insights. Also, we intend to utilize more granular and high-frequency data such as auction-level details and real-time economic indicators to improve model precision and capture subtle market dynamics that influence long-term trends.

## Disclosure

*This research originated from a semester-based seminar project (MATH 451 in 2024) by Samrajya Raj Acharya during his B.Sc. in Computational Mathematics at Kathmandu University. Acharya later independently expanded the initial project beyond curricular requirements into a comprehensive research study, in collaboration with Aayush Man Regmi, by using a larger dataset, additional machine learning models, deeper mathematical and computational analysis, and policy recommendations. Prof. Dr. Kanhaiya Jha provided supervision and is the guarantor of this study.*

## Acknowledgement

*The authors extend their gratitude to Ms. Rabina Bhatta, Assistant Director, Monetary Management Department, Nepal Rastra Bank, for providing valuable insights into the functioning, planning, management and operational aspects of different types of government bonds and securities in the country. The authors also sincerely thank Dr. Birendra Bahadur Budha, Director, Nepal Rastra Bank, for providing suggestions on the documentation aspect of this research.*

## References

- Abhibasu, S., & Choudhury, K. D. (2024). A case study of Gulf Securities Market in the last 20 years: A long short-term memory approach. *Statistica Neerlandica*, 78(1), 136–166.
- Bahdanau, Dzmitry, Cho, Kyunghyun, & Bengio, Yoshua. (2015). Neural machine translation by jointly learning to align and translate. In *International Conference on Learning Representations (ICLR)*.
- Bengio, Y. (2009). Learning deep architectures for AI. *Foundations and Trends in Machine Learning*, 2(1), 1–127.
- Box, G. E. P., Jenkins, G. M., & Reinsel, G. C. (2008). *Time series analysis: Forecasting and control* (4th ed.). Wiley.
- Brockwell, P. J., & Davis, R. A. (1991). *Time series: Theory and methods*. Springer.
- Castellani, M., & Santos, E. (2006). *Forecasting long-term government bond yields: An application of statistical and AI models* (Working Papers Department of Economics, 2006/04). ISEG - Lisbon School of Economics and Management, Universidade de Lisboa.
- Chong, W. P. M., & Soong, V. (2021). Forecasting yield curve with macro-driven models: A comparison between machine learning and traditional statistical approaches. RPubS.
- Dua, P., Raje, N., & Sahoo, S. (2008). Forecasting interest rates in India. *Margin: The Journal of Applied Economic Research*, 2(1), 1–41.
- Elman, J. L. (1990). Finding structure in time. *Cognitive Science*, 14(2), 179–211.
- Fama, E. F. (1970). Efficient capital markets: A review of theory and empirical work. *The Journal of Finance*, 25(2), 383–417.
- Goodfellow, I., Bengio, Y., & Courville, A. (2016). *Deep learning*. MIT Press.
- Hochreiter, S., & Schmidhuber, J. (1997). Long short-term memory. *Neural Computation*, 9(8), 1735–1780.
- Hopfield, J. J. (1982). Neural networks and physical systems with emergent collective computational abilities. *Proceedings of the National Academy of Sciences*, 79(8), 2554–2558.
- Horton, M., & El Ganainy, A. (2025, March). Fiscal policy: Taking and giving away [Back to Basics series]. *Finance & Development Magazine*. International Monetary Fund.
- Hyndman, R. J., & Athanasopoulos, G. (2021). *Forecasting: Principles and practice* (3rd ed.). OTexts.
- International Monetary Fund (IMF). (2021). *Drivers of emerging market bond flows and prices*.
- Li, Z., Wang, B., & Chen, Y. (2024). Incorporating economic indicators and market sentiment effect into US Treasury bond yield prediction with machine learning. *Journal of Infrastructure, Policy and Development*, 8(9), 7671.

- Logubayom, I. A., Nasiru, S., & Luguterah, A. (2013). Modelling the rate of Treasury bills in Ghana. *Mathematical Theory and Modeling*, 3(11), 102–111.
- Mohanty, M. S. (2014). Bond markets and monetary policy dilemmas for the emerging markets. *Bank for International Settlements*.
- Okyere, F., & Nanga, S. (2014). Forecasting weekly auction of the 91-day treasury bill rates of Ghana. *IOSR Journal of Economics and Finance*, 3(5), 46–53.
- Ozturk, H., Kaya, M., & Demir, A. (2020). Forecasting Treasury bond prices in Turkey using ARIMA models. *Emerging Markets Finance and Trade*, 56(12), 2789–2805.
- Petrică, A. C., Stancu, S., & Tindecu, A. (2016). Limitation of ARIMA models in financial and monetary economics. *Theoretical & Applied Economics*, 23(4).
- Public Debt Management Office. (PDMO). (2024). *Monthly debt report: As of February, FY 2024/25*. Government of Nepal, Ministry of Finance.
- Regmi, A. M., & Acharya, S. R. (2025). Deep learning and statistical approaches in financial modeling of foreign assets and liabilities of Nepal's banking system. *Journal of Mathematics and Modeling in Finance*, 5(2), 131–154.
- Rumelhart, D. E., Hinton, G. E., & Williams, R. J. (1986). Learning representations by back-propagating errors. *Nature*, 323, 533–536.
- Siarni-Namini, S., Tavakoli, N., & Siarni Namin, A. (2018). Forecasting economics and financial time series: ARIMA vs. LSTM. *arXiv preprint arXiv:1803.06386*.
- Steger, N., Wegener, C., Basse, T., & Kunze, F. (2021). Mapping swap rate projections on bond yields considering cointegration: An example for the use of neural networks in stress testing exercises. *Annals of Operations Research*, 297(1), 309–321.
- Tu, J. V. (1996). Advantages and disadvantages of using artificial neural networks versus logistic regression for predicting medical outcomes. *Journal of Clinical Epidemiology*, 49(11), 1225–1231.
- Uprety, D., & Chaudhary, S. (2023). Hybrid ARIMA-ANN models for GDP forecasting in Nepal. *NRB Economic Review*.
- Weißbach, R., Ponyatovskyy, V., & Zimmermann, G. (2006). *The yield of ten-year T-bonds: Stumbling towards a "good" forecast* (Technical Report No. 2006,50). Technische Universität Dortmund, Sonderforschungsbereich 475: Komplexitätsreduktion in multi-variablen Datenstrukturen.
- Yao, J., Wang, J., Wang, B., Liu, B., & Jiang, M. (2024). A hybrid CNN-LSTM model for enhancing bond default risk prediction. *Journal of Computer Technology and Software*, 3(6).
- Yu, Y., Kuang, G., Zhu, J., Shen, L., & Wang, M. (2024). Long-term interbank bond rate prediction based on ICEEMDAN and machine learning. *IEEE Access*, 12, 46241–46262.
- Zhuravka, F., Filatova, H., & Aiyedogbon, J. O. (2019). Government debt forecasting based on the ARIMA model. *Public and Municipal Finance*, 8(1), 120–127.

## Appendix - I

Source: Author's Calculation

### ARIMA Forecast of Development Bonds (In Million Rupees)

Year	Forecast Amount	CI Lower	CI Upper
2025	867447.00	825053.90	909840.10
2026	972947.00	878153.20	1067741
2027	1078447.00	919826.70	1237067
2028	1183947.00	951750.60	1416143
2029	1289447.00	975051.70	1603842
2030	1394947.00	9905430	1799351
2031	1500447.00	998845.60	2002048
2032	1605947.00	1000453	2211441

### ARIMA Forecast of Treasury Bills (In Million Rupees)

Year	Forecast Amount	CI Lower	CI Upper
2025	395679.812340	340593.001482	450766.623197
2026	401834.989137	311169.058832	492500.919442
2027	412343.136569	293254.603571	531431.669567
2028	424188.730067	281384.185987	566993.274147
2029	436445.252590	273099.555244	599790.949937
2030	448828.032664	267184.311837	630471.753491
2031	461249.605249	262970.932310	659528.278188
2032	473683.096796	260055.647397	687310.546194

### ARIMA Forecast of Citizen Saving Bonds (In Million Rupees)

Year	Forecast Amount	CI Lower	CI Upper
2025	11597.009091	8917.572798	14276.445384
2026	12073.918182	8284.623037	15863.213327
2027	12550.827273	7909.907477	17191.747068
2028	13027.736364	7668.863777	18386.608950
2029	13504.645455	7513.243762	19496.047147
2030	13981.554545	7418.302829	20544.806262

### ARIMA Forecast of Foreign Employment Bonds (In Million Rupees)

Year	Forecast Amount	CI Lower	CI Upper
2025	210.120765	72.947990	347.293540
2026	205.143506	30.162955	380.124057
2027	211.994859	26.782702	397.207016
2028	228.339347	43.688063	412.990631

## Deep Learning Forecast for Development Bonds (In Million Rupees)

Year	RNN Forecast Amount	LSTM Forecast Amount
2025	1187930	4033741
2026	2012925	24295560
2027	2908359	174144200
2028	3933782	1306774000
2029	6030670	9756769000
2030	10577650	72578760000
2031	17912130	540862100000
2032	28212970	4029303000000

## Deep Learning Forecast for Treasury Bills (In Million Rupees)

Year	RNN Forecast Amount	LSTM Forecast Amount
2025	321506.125	194449.843
2026	277426.906	197109.531
2027	243852.968	171840.750
2028	218711.828	141821.593
2029	199700.046	139193.484
2030	185348.562	132947.234
2031	174293.468	128035.304
2032	165678.921	126992.070

## Deep Learning Forecast for Citizen Saving Bonds (In Million Rupees)

Year	RNN Forecast Amount	LSTM Forecast Amount
2025	10570.833	12389.220
2026	9707.208	14307.680
2027	8637.492	18691.300
2028	218711.828	32026.710
2029	6250.468	106156.500
2030	5034.842	590246.200

## Deep Learning Forecast Amount for Foreign Employment Bonds (In Million Rupees)

Year	RNN Forecast Amount	LSTM Forecast Amount
2025	275.053	235.074
2026	310.708	240.497
2027	8637.492	244.196
2028	335.706	246.748
2029	352.607	248.523

## ADF Statistics and p-value for Each Sub-heading

Financial Indicators	ADF Statistics	p-value
Total Bonds & Treasury Bills	-0.264	0.930
Development Bonds	1.125	0.995
Treasury Bills	2.676	0.999
Citizen Saving Bonds	0.667	0.989
Foreign Employment Bonds	-17.278	0.000

Statistical Tests Results for ARIMA

Indicators	ARIMA (p,d,q)	No. of Observations	Log Likelihood	AIC	BIC	HQIC
Total Bonds and Treasury Bills	(0,2,0)	32	-353.052	708.105	709.506	708.533
Development Bonds	(0,2,0)	32	-343.023	688.045	689.446	688.493
Treasury Bills	(1,1,0)	32	-361.096	7288.192	732.494	729.595
Citizen Saving Bonds	(0,1,0)	23	-190.066	384.132	386.315	384.646
Foreign Employment Bonds	(2,0,1)	15	-86.841	183.682	187.222	183.644

ARIMA Results of the Financial Indicators

Indicators	Variables	Coefficients	Standard error	Z	P> z	0.025	0.975
Total Bonds and Treasury Bills	$\sigma^2$	9.130e+08	1.36e+08	6.731	0.000	6.470e+08	1.180e+09
Development Bonds	$\sigma^2$	4.678e+08	6.460e+07	7.247	0.000	3.410e+08	5.940e+08
Treasury Bills	Intercept	8616.975	9706.807	0.888	0.375	-1.040e+04	2.76e+04
	AR (L1)	0.307	0.127	2.421	0.015	0.059	0.556
	$\sigma^2$	7.899e+08	0.398	1.99e+09	0.000	7.910e+08	7.9e+08
Citizen Saving Bonds	Intercept	476.909	372.565	1.280	0.201	-253.304	1207.122
	$\sigma^2$	1.869e+06	5.030e+05	3.718	0.000	8.840e+05	2.85e+06
Foreign Employment Bonds	Intercept	50.740	34.053	1.490	0.136	-16.002	117.483
	AR (L1)	1.721	0.117	14.657	0.000	1.492	1.952
	AR (L2)	-0.913	0.141	-6.467	0.000	-1.191	-0.637
	MA (L1)	-0.956	1.751	-0.546	0.585	-4.388	2.475
	$\sigma^2$	4752.5453	8818.851	0.539	0.590	-1.25e+04	2.2e+04

Where e is an exponential term, represented as a power of 10.

ARIMA Equations for Each Financial Indicators

Indicators	Equation
Total Bonds and Treasury Bills	$y_t = 2y_{t-1} - y_{t-2} + \epsilon_t, \epsilon_t \sim N(0, 9.130 \times 10^8)$
Development Bonds	$y_t = 2y_{t-1} - y_{t-2} + \epsilon_t, \epsilon_t \sim N(0, 4.678 \times 10^8)$
Treasury Bills	$y_t = 8616.980 + 0.3072 y_{t-1} + \epsilon_t, \epsilon_t \sim N(0, 7.899 \times 10^8)$
Citizen Saving Bonds	$y_t = y_{t-1} + 476.9091 + \epsilon_t, \epsilon_t \sim N(0, 1.869 \times 10^6)$
Foreign Employment Bonds	$y_t = 50.740 + 1.722 y_{t-1} - 0.914 y_{t-2} - 0.956 \epsilon_{t-1} + \epsilon_t, \epsilon_t \sim N(0, 4752.5453)$

RNN Model Performance (In Million Rupees)

Performance Metrics	Total	Development	Treasury	Citizen	Foreign
MAE Train	7378.32	4073.01	5499.67	1672.99	59.16
MSE Train	120198441.01	60163211.75	52840399.72	3627069.31	8979.06
RMSE Train	10963.50	7756.49	7756.49	1904.49	94.76
MAE Test	146707.95	71493.40	89805.01	425.09	38.48
MSE Test	25114951773.33	7782832512.46	11409566845.25	871266.74	2502.16
RMSE Test	158476.90	88220.36	106815.57	933.42	50.02

LSTM Model Performance (In Million Rupees)

Performance Metrics	Total Bonds and Treasury Bills	Development Bonds	Treasury Bills	Citizen Saving Bonds	Foreign Employment Bonds
MAE Train	15792.06	11129.68	7253.18	7253.18	74.73
MSE Train	411907168	313503648	73661640	73661640	10386.35
RMSE Train	20295.50	17706.04	8582.64	8582.64	101.91
MAE Test	355477.72	241283.23	133497.56	133497.56	86.87
MSE Test	147354353664	171649417216	27906758656	27906758656	14282.16
RMSE Test	383867.62	414305.94	167053.16	167053.16	119.51



# Appendix – II

Source: Author's Calculation

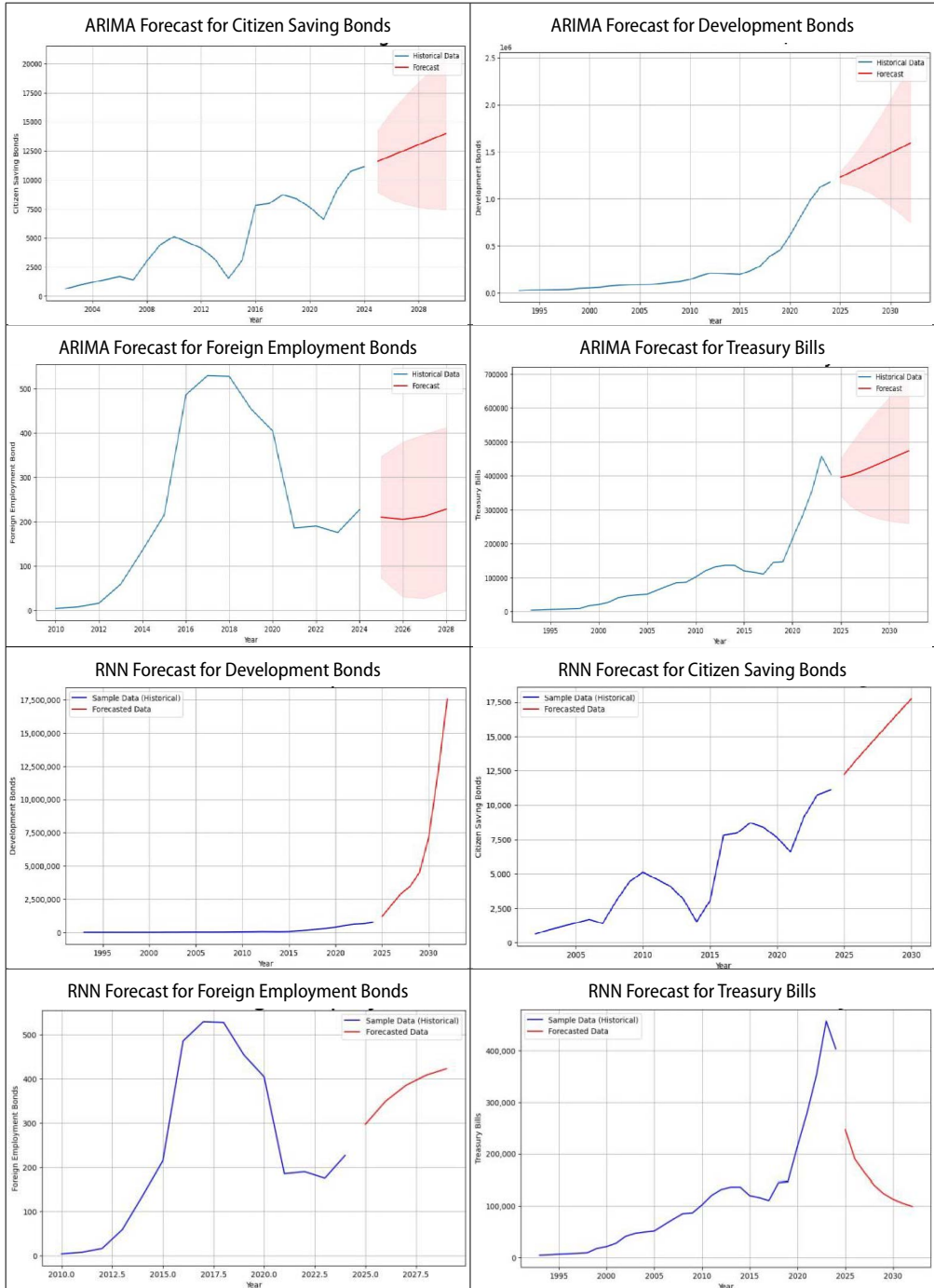

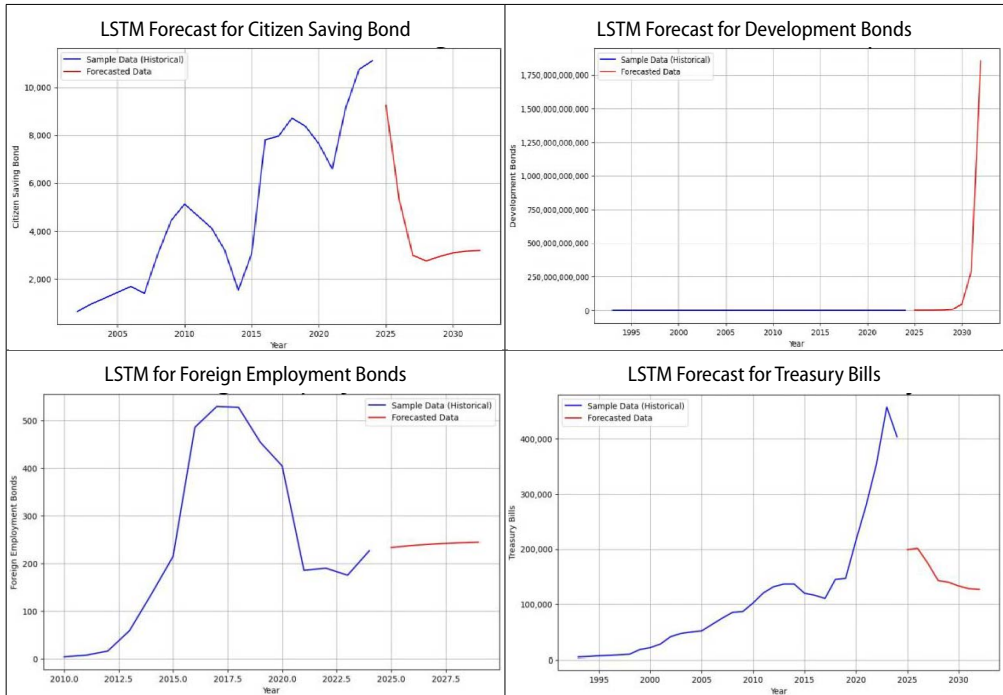

ACF and PACF plot for Total Bonds & Treasury Bills

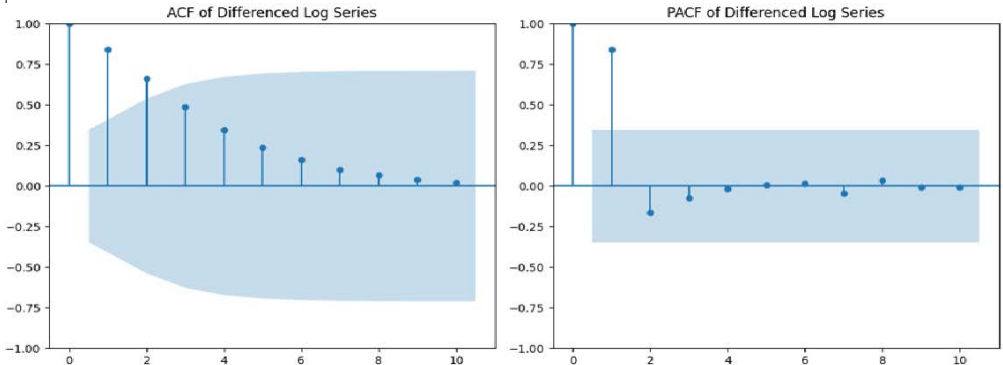

ACF and PACF plot for Citizen Saving Bonds

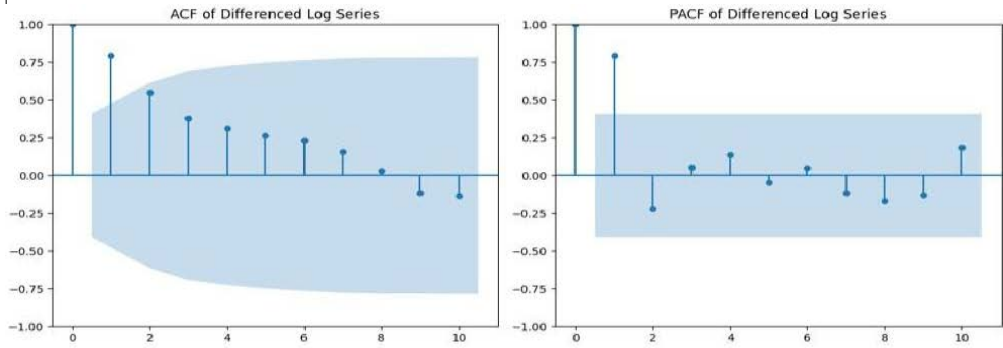



### ACF and PACF plot for Foreign Employment Bonds

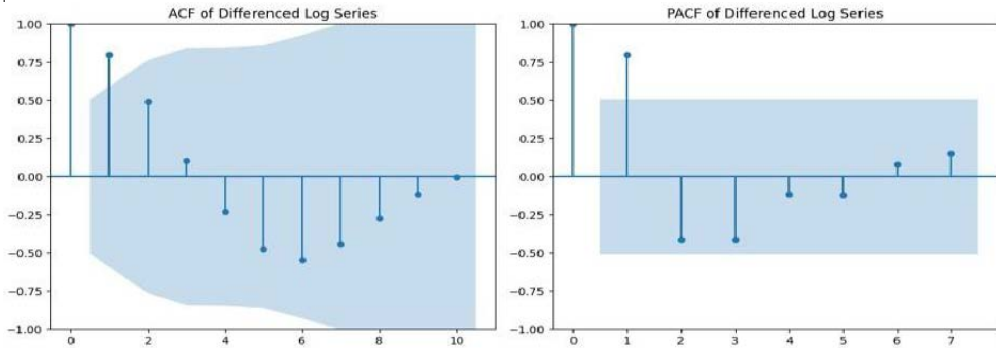

### ACF and PACF plot for Development Bonds

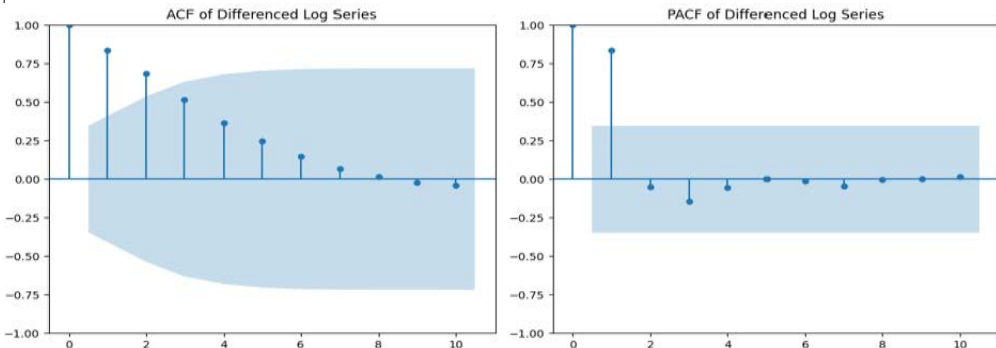

### ACF and PACF plot for Treasury Bills

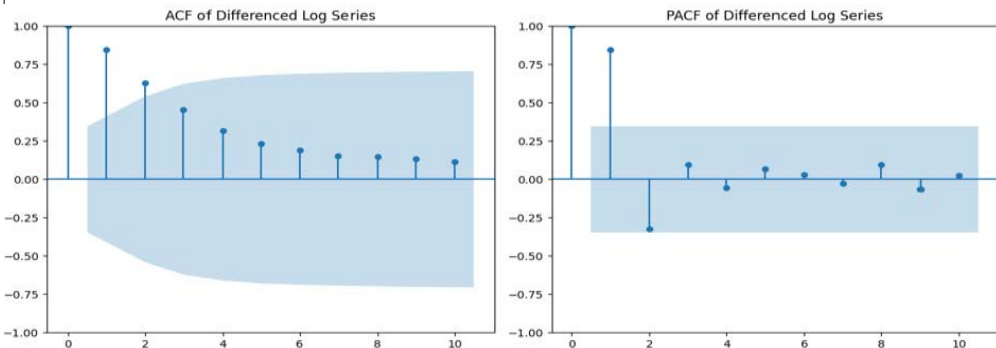

### RRN and LSTM Loss graph for Total Bonds & Treasury Bills

